

Product data sheet

Characteristics

XMLP250BD71F

Electronic pressure sensors, Pressure sensors XM, transmitter, XMLP, 250 bar, G1/4 A male, 0...10 V, M12, set of 1



Product availability: Non-Stock - Not normally stocked in distribution facility

Price*: 105.00 USD



Main

Range of product	OsiSense XM
Product or component type	Electronic pressure sensors
Pressure sensor type	Pressure transmitter
Pressure sensor name	XMLP
Electrical circuit type	Control circuit
Pressure sensor size	3625.94 Psi (250 bar)
Local display	Without
Current consumption	< 7 mA
Type of output signal	Analogue
Quantity per set	Set of 1
Type of packing	Individual

Complementary

Pressure setting range	0.00...3625.94 Psi (0...250 bar)
Maximum permissible accidental pressure	10877.83 Psi (750 bar)
Destruction pressure	21755.66 Psi (1500 bar)
Materials in contact with fluid	Stainless steel AISI 316L Fluorocarbon FPM
Operating position	Any position
Protection type	Load short-circuit Reverse polarity
[Uimp] rated impulse withstand voltage	0.5 KV
Measurement accuracy	+/- 0.5 % of the measuring range
Accuracy	0.1 % of the measuring range
Drift of the sensitivity	+/- 0.02 % of measuring range/°K
Drift of the zero point	+/- 0.02 % of measuring range/°K
Mechanical durability	10000000 Cycles
Net weight	0.21 Lb(US) (0.094 kg)

Diameter	1.02 In (26 mm)
Length	1.50 In (38.1 mm)

Environment

Standards	NSF ANSI 61 EN/IEC 61326-2-3
Product certifications	CE EAC CULus RCM
Protective treatment	TC
Ambient air temperature for operation	-22...185 °F (-30...85 °C)
Ambient air temperature for storage	-58...212 °F (-50...100 °C)

Ordering and shipping details

Category	22419 - PRESSURE SWITCH IEC (HIGH,LOW,GEN)
Discount Schedule	DS2
GTIN	3389119639910
Nbr. of units in pkg.	1
Package weight(Lbs)	3.32 Oz (94 g)
Returnability	No

Packing Units

Unit Type of Package 1	PCE
Package 1 Height	1.57 In (4 cm)
Package 1 width	3.23 In (8.2 cm)
Package 1 Length	1.81 In (4.6 cm)
Unit Type of Package 2	S01
Number of Units in Package 2	24
Package 2 Weight	5.52 Lb(US) (2.503 kg)
Package 2 Height	5.91 In (15 cm)
Package 2 width	5.91 In (15 cm)
Package 2 Length	15.75 In (40 cm)

Offer Sustainability

Sustainable offer status	Green Premium product
California proposition 65	WARNING: This product can expose you to chemicals including: Diisononyl phthalate (DINP), which is known to the State of California to cause cancer, and Diisodecyl phthalate (DIDP), which is known to the State of California to cause birth defects or other reproductive harm. For more information go to www.P65Warnings.ca.gov
REACH Regulation	REACH Declaration
EU RoHS Directive	Pro-active compliance (Product out of EU RoHS legal scope) EU RoHS Declaration
Mercury free	Yes
RoHS exemption information	Yes
Environmental Disclosure	Product Environmental Profile

Dimensions

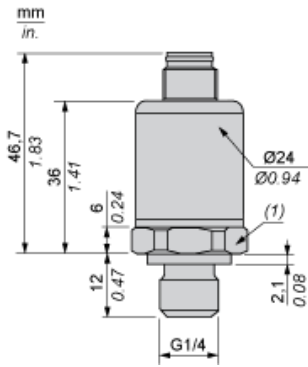

(1) SW24 tightening torque ≤ 25 N.m / 221 lb-in

Wiring Diagram

3-Wire Technique (0-10 V)

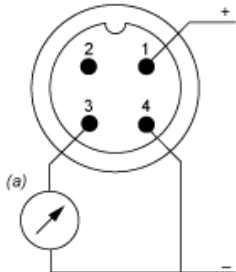

(a) V out

Curves

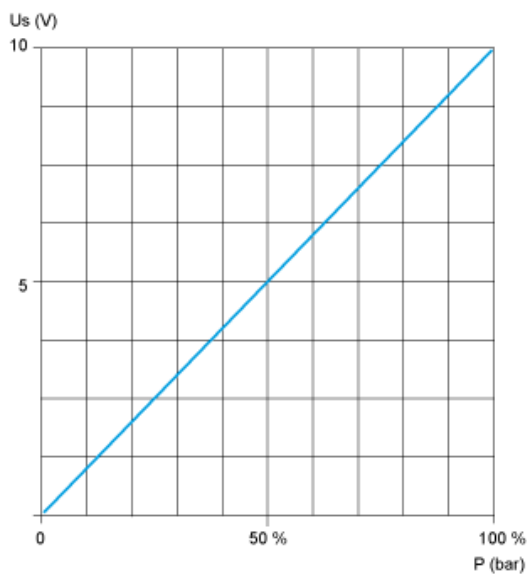

Product Life Status : Commercialised